

Model 535H Pressure Regulator for Reducing and Differential Service

Steam, Gas or Liquid Service

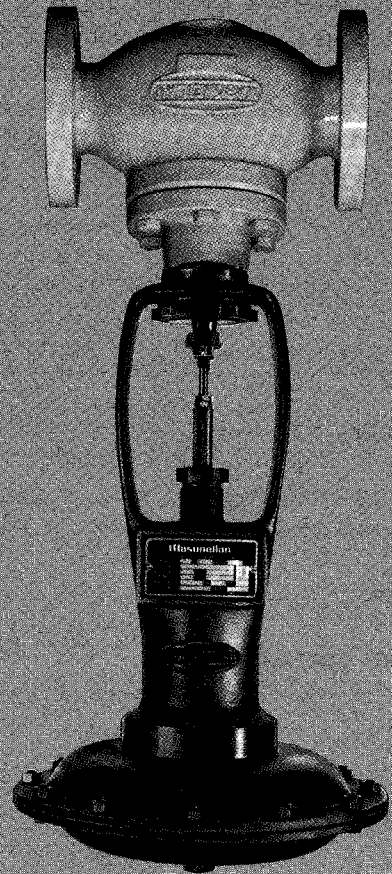

Masoneilan

DRESSER

Table of Contents

General Data	2
Ratings (ANSI)	3
Body Materials , ANSI Ratings and End Connections	3
Trim Materials	3
Bonnet Packing	3
Flow Coefficients - C _v	3
Regulator Sizing	
Regulator Capacity - Steam	4
Regulator Capacity - Air	5
Regulator Capacity - Water	6
Materials	7
Dimensions	8
Weights	8

Foreword

The Model 535H pressure regulators are designed to provide accurate reduced pressures of air, liquid, saturated and superheated steam. They are available in sizes 3/4", 1", 1 1/2" and 2" with full area and reduced trim to handle the small-to-moderate flow applications where ANSI B 16.104 Class IV or VI shut-off is required.

For temperatures over the rating of the diaphragm material, the regulator must be mounted with the actuator below the centerline of the regulator body. The diaphragm will be protected from the high temperature by a condensate barrier in the sensing line and actuator diaphragm case. If installed otherwise, an adequate condensate barrier must be incorporated. Consult factory for more information.

Refer to Specification Data CY5010 for actuator selection.

General Data

• Function

pressure reducing	535H
differential pressure reducing	535H-50

• Service

steam, gas, liquids

• Body

type:	high capacity globe
flow direction:	flow-to-open

• Bonnet

type: bolted, standard

• Body and Bonnet

materials:	carbon steel
	316 stainless steel
	chrome-molybdenum steel

• Trim

plug type:	disc
seat ring:	threaded
guide:	heavy top guided
capacity:	full area, reduced capacity in all sizes
characteristic:	quick opening

• Actuator

type: 10900 Series

Body Materials, ANSI Ratings and End Connections

Body Material	ANSI Ratings	End Connections	Size (Inches)			
			³ / ₄	1	1 ¹ / ₂	2
Carbon Steel	Class 150	Raised Face Flange	•	•	•	•
	Class 300	Raised Face Flange	•	•	•	•
Stainless Steel	Class 300	Ring Type Joint			•	•
	Class 600	Threaded	•	•	•	•
	Class 600	Raised Face Flange	•	•	•	•
	Class 600	Ring Type Joint	•	•	•	•
For availability of other alloys consult factory	Class 600	Socket Weld	•	•	•	•

Trim Materials

Type	Plug	Seat Ring
Standard	316 St. St.	316 St. St.
Hard	316 St.St. w/hardfacing	316 St. St. w/hardfacing
Soft	316 St. St. w/Teflon® Insert	316 St. St.

Bonnet Packing

Packing Material	Remarks
Crane 285K (PTFE & Aramid)	-20°F to 450°F
Flexible Graphite	450°F to 800°F
Chesterton 324 (100% Teflon® Ring)	-20°F to 450°F

Flow Coefficients - C_v (Critical Flow Factor - $C_f = 0.9$)

Orifice Size/inches Body Size/inches	0.250	0.375	0.500	0.810	1.250	1.625
	Rated C_v					
³ / ₄	1.4	2.4	4.4	6.5	--	--
1	1.4	2.4	4.4	6.5	--	--
1 ¹ / ₂	1.4	2.4	4.4	6.5	19.5	27
2	1.4	2.4	4.4	6.5	19.5	27

Regulator Sizing

Model 535H Series Pressure Reducing Regulators Capacity^① - Saturated Steam (lb/hr)

Inlet Pressure psig	Outlet Pressure psig	Orifice Size (inches)					
		0.250 (Cv=1.4)	0.375 (Cv=2.4)	0.500 (Cv=4.4)	0.810 (Cv=6.5)	1.25 (Cv=19.5)	1.625 (Cv=27)
30	1/2-10	110	187	344	508	1526	2112
	20	83	142	260	384	1154	1601
50	1/2-20	161	275	505	745	2236	3096
	30	138	235	432	638	1915	2652
	40	101	174	319	472	1415	1959
60	1/2-25	186	319	584	864	2591	3588
	40	150	256	470	695	2083	2884
	50	110	188	345	509	1529	2117
75	1/2-30	229	392	719	1062	3185	4409
	50	183	313	574	848	2544	3522
	60	146	250	459	678	2033	2816
100	1/2-50	278	477	875	1292	3878	5370
	60	256	438	804	1188	3564	4935
	80	190	326	598	883	2650	3670
125	1/2-60	347	595	1084	1611	4834	6693
	80	302	518	949	1402	4206	5823
	100	235	402	737	1088	3265	4522
150	1/2-70	415	712	1305	1928	5784	8009
	100	348	595	1092	1613	4840	6701
	125	256	440	806	1191	3572	4946
160	1/2-80	432	740	1357	2004	6011	8323
	100	387	664	1217	1799	5396	7471
	120	327	560	1028	1518	4555	6308
	140	239	409	750	1108	3324	4602
175	1/2-90	465	797	1461	2159	6478	8969
	100	444	761	1396	2063	6187	8567
	125	377	647	1186	1770	5255	7277
	160	217	372	683	1009	3027	4192
200	1/2-100	534	915	1677	2477	7432	10290
	125	479	822	1506	2225	6676	9244
	160	367	629	1153	1703	5110	7076
225	1/2-120	583	999	1832	2706	8119	11242
	160	483	957	1516	2240	6720	9305
250	1/2-130	651	1117	2048	3025	9076	12567
	160	585	1002	1838	2714	8143	10812

① Regulator Capacity Tables are included to provide convenience on common applications and are not intended to establish application limitations. If your particular service conditions are not listed in the Regulator Capacity Table, calculate the required Cv for selecting the optimum regulator size.

Regulator Sizing

Model 535H Series Pressure Reducing Regulators Capacity^① - Air (scfm)

Inlet Pressure psig	Outlet Pressure psig	Orifice Size (inches)					
		0.250 (Cv= 1.4)	0.375 (Cv=2.4)	0.500 (Cv=4.4)	0.810 (Cv=6.5)	1.25 (Cv=19.5)	1.625 (Cv=27)
30	1/2-10	36	62	114	172	506	701
	20	27	47	87	130	383	531
50	1/2-20	54	91	167	252	742	1028
	30	45	78	144	216	636	880
	40	34	58	106	160	470	650
60	1/2-25	62	106	194	292	860	1191
	40	49	85	156	235	692	957
	50	36	62	114	173	508	703
75	1/2-30	76	130	238	359	1057	1463
	50	61	104	191	287	845	1169
	60	49	83	153	229	675	935
100	1/2-50	92	158	271	438	1288	1783
	60	85	146	267	402	1183	1638
	80	63	108	199	299	880	1218
125	1/2-60	115	198	362	545	1605	2222
	80	100	172	315	474	1396	1933
	100	78	134	245	368	1084	1501
150	1/2-70	138	236	433	652	1920	2659
	100	115	198	362	546	1607	2225
	125	85	146	268	403	1186	1642
160	1/2-80	143	246	450	678	1996	2763
	100	115	198	362	608	1791	2480
	120	109	186	341	514	1513	2094
	140	79	136	249	375	1103	1528
175	1/2-90	154	265	485	730	2150	2978
	100	147	253	463	698	2054	2844
	125	125	215	394	592	1744	2416
	160	72	184	227	341	1005	1392
200	1/2-100	177	304	557	838	2467	3417
	125	159	273	500	753	2217	3069
	160	122	209	383	576	1696	2349
225	1/2-120	194	331	608	916	2695	3732
	160	161	274	504	758	2231	3089
250	1/2-130	217	371	672	1023	3013	4172
	160	194	333	610	918	2703	3743

① Regulator Capacity Tables are included to provide convenience on common applications and are not intended to establish application limitations. If your particular service conditions are not listed in the Regulator Capacity Table, calculate the required Cv for selecting the optimum regulator size.

Regulator Sizing

Model 535H Series Pressure Reducing Regulators Capacity^① - Water (GPM)

Inlet Pressure minus Outlet Pressure	Orifice Size (inches)					
	0.250 (Cv=1.4)	0.375 (Cv=2.4)	0.500 (Cv=4.4)	0.810 (Cv=6.5)	1.25 (Cv=19.5)	1.625 (Cv=27)
10	4	8	14	20	62	86
15	6	9	17	25	75	105
20	7	11	20	29	87	121
25	8	12	22	33	97	135
30	8	13	24	36	107	148
35	8	14	26	38	116	160
40	9	15	28	41	123	170
45	9	16	29	43	131	181
50	10	17	31	46	138	191
60	11	19	34	50	151	209
70	12	20	37	54	163	226
80	13	21	40	58	174	241
90	13	23	42	62	185	256
100	14	24	44	65	195	270
120	16	27	48	71	214	295
140	17	29	52	77	231	319
160	18	30	56	82	247	342
180	19	32	59	87	262	363
210	21	35	64	94	283	391
230	22	36	67	98	296	410

① Regulator Capacity Tables are included to provide convenience on common applications and are not intended to establish application limitations. If your particular service conditions are not listed in the Regulator Capacity Table, calculate the required Cv for selecting the optimum regulator size.

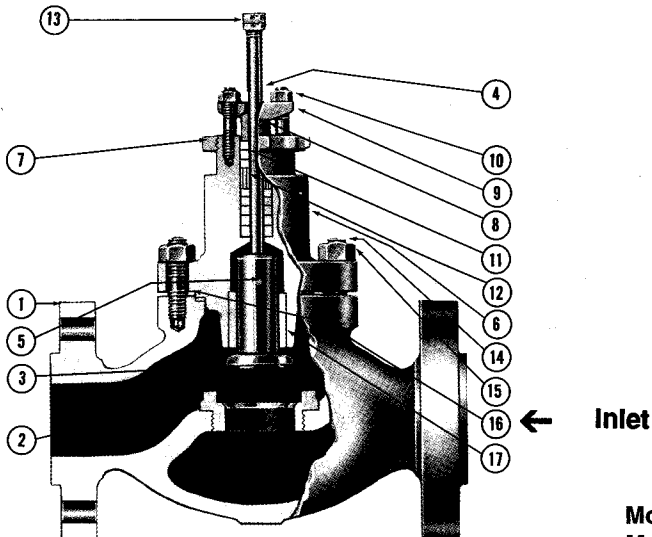

Model 535H Reducing Valve
Model 535H-50 Differential Pressure Reducing Regulator

Materials 3/4"-2" ANSI Class 150-600

Ref. No.	Part Description	Standard Materials
1	Body	Carbon Steel ASTM A216 Gr WCB
		316 St. St. ASTM A351 GR CF8M
2	Seat Ring Threaded	316 St. St. ASTM A351 Gr CF8M with or without hardfacing
		416 St. St. ASTM A582 TY 416
3	Valve Plug	316 St. St. ASTM A479 TY 316 with or without hardfacing
		416 St. St. ASTM A582 TY 416 or AISI 416
		316 St. St ASTM A479 TY 316 Teflon Soft Seat
4	Plug Stem	316 St. St. ASTM A479 TY 316
5	Plug Pin	316 St. St. ASTM A276 TY 316
6	Bonnet	Carbon Steel ASTM A216 Gr WCB
		316 St. St. ASTM A351 Gr CF8M
7	Drive Nut	SAE 1117
8	Packing Follower	303 St. St. ASTM A582 TY 303
9	Packing Flange	Steel ASTM A668 CL B Cadmium Plated
10	Packing Box Stud Nuts	304 St. St. ASTM A194 Gr 8
11	Packing	Crane 285K (PTFE & Aramid)
		Chesterton 324 (100% Teflon Ring)
		Flexible Graphite
12	Packing Spacer	303 St. St. ASTM A582 TY 303
13	Stem Locknut	Carbon Steel
14	Valve Body Studs	Alloy Steel ASTM A193 Gr B7
15	Valve Body Stud Nuts	Alloy Steel ASTM A194 Gr 2H
16	Valve Body Gasket	Spiral Wound St. St. w/Graphite filler
17	Guide Bushing	440C St. St. ASTM A276 TY 440C Heat Treated
		No. 6 Stellite (Used w/316 St. St. Bonnet)

Trade names noted throughout text are for reference only. Masoneilan reserves the right to supply trade named material or equivalent.

Dimensions - Inches

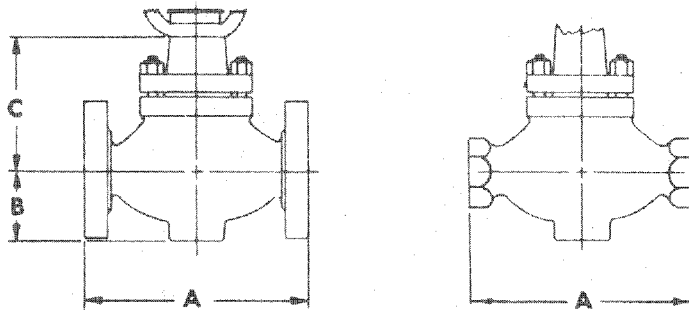

Size (in.)	A							B	C
	ANSI Class 150		ANSI Class 300		ANSI Class 600		ANSI Class 150-600 Butt Weld Socket Weld & Threaded Ends		
	Raised Face	Ring Type Joint	Raised Face	Ring Type Joint	Raised Face	Ring Type Joint			Std Bon
3/4	7.24	--	7.62	8.12	8.12	8.12	8.24	2.00	5.00
1	7.24	7.76	7.76	8.24	8.24	8.24	8.24	2.00	5.50
1 1/2	8.76	9.24	9.24	9.76	9.88	9.88	9.88	2.50	5.50
2	10.00	10.50	10.50	11.12	11.24	11.38	11.24	3.00	5.50

Net Body Weight (lb.) - Actuator not included

Size (inches)	ANSI Class		
	150 300 Flanged	600 Flanged	600 Threaded Socket Weld
3/4	36	38	27
1	36	38	27
1 1/2	49	52	35
2	57	63	45

The actuator weight varies according to range. To determine the total weight of regulator with actuator included, add the actuator weight listed in Specification Data CY5010.