

# Wee Willie Model 5061 Control Valve

For low flow,  
high pressure applications

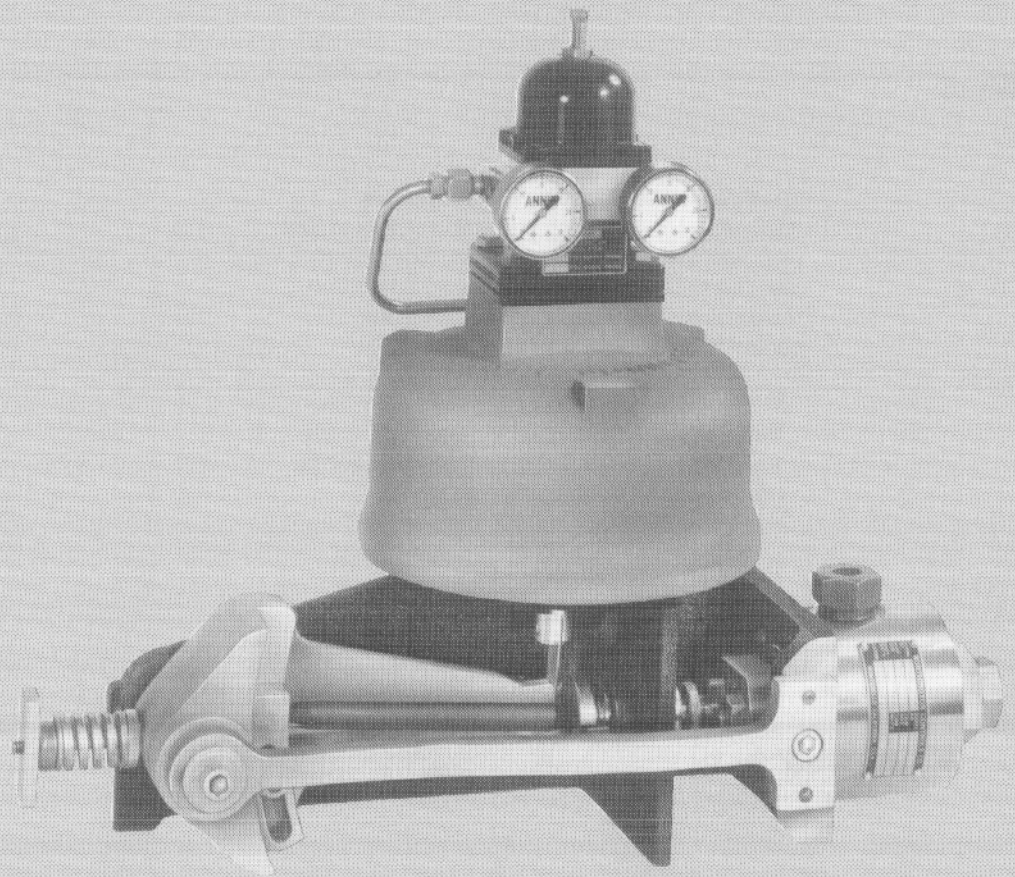

**Masoneilan**

**DRESSER**

## Table of Contents

---

General Data .....	1
Flow Coefficients (rated $C_v$ ) .....	1
Critical Flow Factor $C_f$ (FL) .....	1
Material .....	3
Availability .....	4
Weight .....	4
Dimensions .....	4
How to Specify .....	5

## Foreword

---

The Model 5061 Wee Willie Control Valve is designed for applications in the laboratory and pilot plant where very low flow rates and high operating pressures are encountered. Unique construction features have been selected to provide precise control of these applications.

Features include:

- **Variable Ratio Linkage**  
Provides the power and rangeability required for precise control of high pressure, low flow applications.
- **Domotor<sup>®</sup> actuator**  
Has stiffness, long stroke for smooth control, speed and high thrust.
- **Field reversible**  
Air action may be reversed in the field without any additional parts.
- **Adjustable stroke**  
Allows a full  $C_v$  range from 0.000001 to 1.0 with five (5) trim sets.

## General Data

---

### body

---

**type:** angle  
**end connections:**  $\frac{9}{16}$ " O.D.,  $\frac{3}{8}$ " O.D.,  $\frac{1}{4}$ " O.D. high pressure tubing, or  $\frac{9}{16}$ " O.D. nipple with  $\frac{1}{4}$ " NPT male thread  
**rating:** inlet—50000 psi @ 100°F  
 outlet—30000 psi @ 100°F  
**materials:** ASTM A479 (Type 316 St. St.) other alloys available  
**C<sub>v</sub> ratio:** in excess of 100:1  
**flow direction:** flow-to-open

### bonnet

---

**type:** standard and plain extension

### trim

---

**type:** stem and port guided  
**materials:** alloy 25 or Stellite plug; alloy 25, Stellite or Hastelloy C seat  
**packing box:** bolted  
**packing:** Teflon® v-ring with O-ring backup

### actuator

---

**\*type:** positioning pneumatic cylinder with integral positioner  
**material:** cast aluminum  
**action:** increasing signal retracts stem  
**supply air:** 30 psig  
**connections:**  $\frac{1}{4}$ " NPT  
**instrument signal:** common full and split range signals  
**loading pressure:** depends on available supply pressure and process conditions  
**gauges:** instrument, supply and loading with English and Metric scales  
**static air consumption:** 0.5 SCFM @ 60 psi supply

### temperature range

---

**standard bonnet:** -20°F to +465°F  
**extended bonnet:** -320°F to +1000°F

### seat leakage

---

ANSI B16.104 Class V

\* See Masoneilan Specification Data CR4000E, Type 71 Domotor® for additional information.

## Flow Coefficients—Rated C<sub>v</sub>

---

Trim Set "AA" — 0.000001 to 0.001  
 Trim Set "A" — 0.0001 to 0.01  
 Trim Set "B" — 0.001 to 0.1  
 \*Trim Set "C" — 0.01 to 0.5  
 \*Trim Set "D" — 0.02 to 1.0  
 \*Limited to 20000 psi operation

## Critical Flow Factor C<sub>f</sub>(FL)

---

Trim Sets "AA" and "A"—0.8  
 Trim Sets "B", "C", "D"—0.9

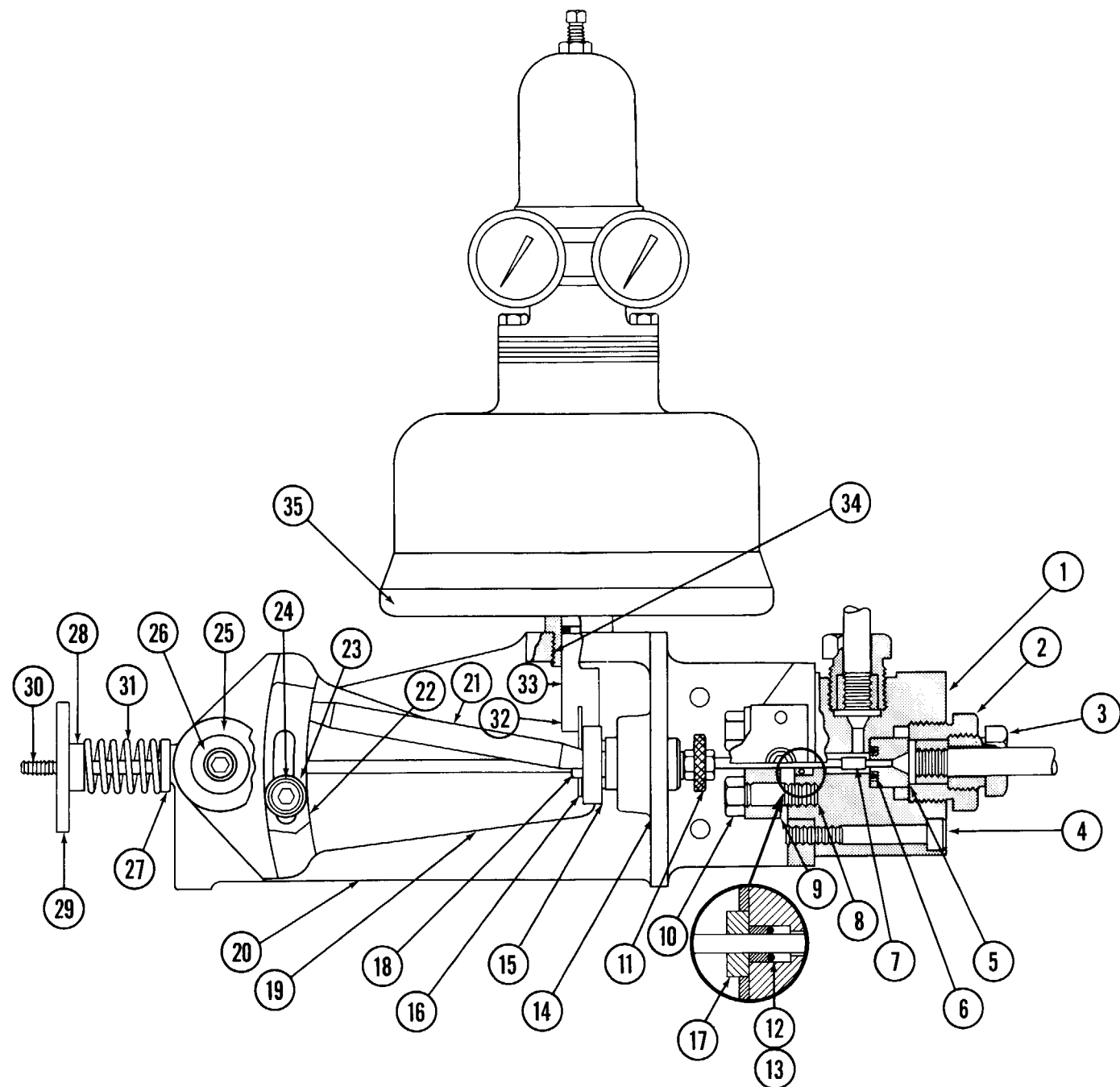

**Material**

Part No.	Temperature ► Part Name	-320°F	-20°F	+465°F	+1000°F
		Standard Materials			
1	Body /Extended Bonnet	316 St. St.			316 St. St.
	Body/Standard Bonnet		316 St.St.		
2	Seat Retainer Nut	Carbon Steel			
3	Tube Retainer Nut	Carbon Steel			
4	Socket Head Cap Screw	Alloy Steel			
5	Seat Ring	Alloy 6; Hastelloy C; Alloy 25			
6	Seat Ring Gasket	Inconel X			
7	Plug and Stem Assembly	Alloy 6; Alloy 25			
8	Gland Flange Stud	304 St. St. ASTM A194 Gr 8F			
9	Gland Flange	303 St. St.			
10	Gland Flange Nut	304 St. St. ASTM A194 Gr 8F			
11	Finger Nut	303 St. St.			
12	V-ring Packing	Teflon			
13	O-ring Packing	Teflon			
14	Ball Bushing	St. St./Brass			
15	Guide	17-4 PH St. St.			
16	Reed	304 St. St.			
17	Packing Gland	Aluminum Bronze			
18	Hex Nut	303 St. St. ASTM A194 Gr 8F			
19	Lever Assembly	Carbon Steel			
20	Frame Assembly	Carbon Steel			
21	Push Rod	440-C St. St.			
22	Shoe	Carbon Steel			
23	Washer	Carbon Steel			
24	Socket Head Cap Screw	Alloy Steel			
25	Retainer Washer	Carbon Steel			
26	Socket Head Cap Screw	Alloy Steel			
27	Spacer	Carbon Steel			
28	Thrust Bearing	Carbon Steel			
29	Tension Nut	Carbon Steel			
30	Pull Rod	ASTMA193 Gr B7			
31	Pullback Spring	Carbon Steel			
32	Set Screw	Alloy Steel			
33	Piston Rod	303 St. St.			
34	MTG Adapter	Aluminum Bronze			
35	Hex Nut	Carbon Steel			

Trade names noted throughout text are for reference only.  
Masoneilan reserves the right to supply trade named material or equivalent.

## Availability

Shaded areas indicate product combinations within standard delivery cycle.  
For other combinations, contact your Masoneilan Representative.

### Body Type

Angle	
-------	--

### Body Material

316 St. St. ASTM A 479	
other alloys	

### Rating

50000 psi @ 100°F	
-------------------	--

### End Connections

9/16" O.D.	
3/8" O.D.	
1/4" O.D.	
9/16" O.D. Nipple w/ 1/4" NPT Male Thread	

### Trim

"AA" - 0.000001 to 0.001	
"A" - 0.0001 to 0.01	
"B" - 0.001 to 0.1	
* "C" - 0.01 to 0.5	
* "D" - 0.02 to 1.0	

\* Limited to 20000 psi operation

## Dimensions (Inches)

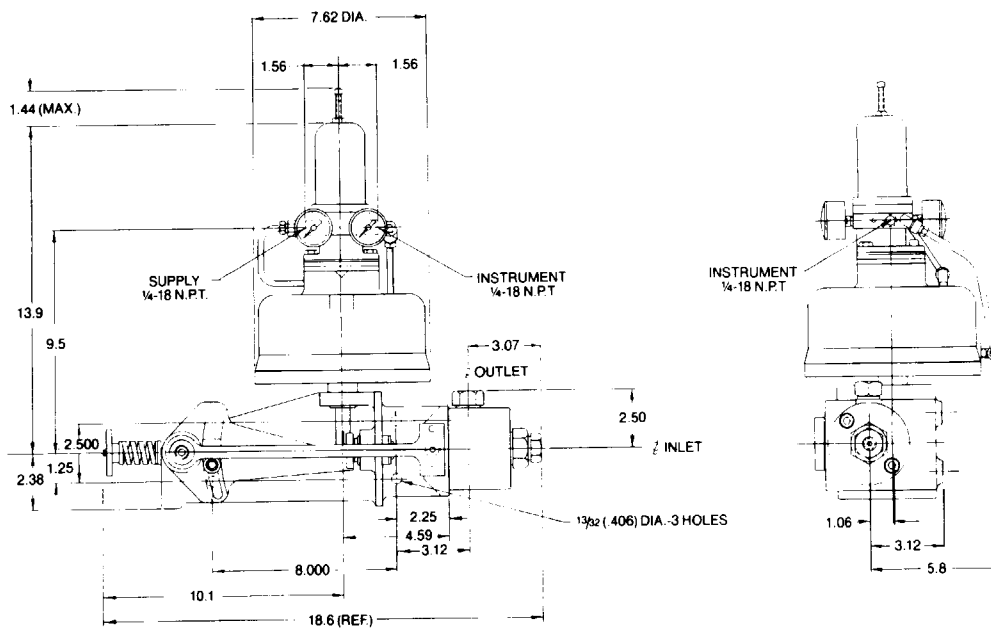

## Weight (lb)

Valve Size in.	Rating 50000 psi Threaded	Volume Cubic Ft
1/4, 3/8 & 1/2	25	3.6

## How To Specify Your 5061 Series Control Valve

### Specification Data

The checklist provided below contains the necessary data to specify the basic 5061 Series Control Valve. The page references will refer you to the appropriate sections when a selection is to be made.

Quantity:	Size:	Model:	
<b>Body</b>	Type	Angle	
	Material (page 3)	316 St. St.	
	Rating (page 1)	Inlet 50000 psi@100°F <input type="checkbox"/> Outlet 30000 psi@100°F <input type="checkbox"/>	
	Connections (page 1)	HP Tube <input type="checkbox"/> 1/4" <input type="checkbox"/> 3/8" <input type="checkbox"/> 9/16" <input type="checkbox"/> 1/4" NPT Male <input type="checkbox"/>	
<b>Bonnet</b>	Type	Extension <input type="checkbox"/> Standard <input type="checkbox"/>	
	Packing	Teflon V-Ring	
<b>Trim</b>	Size	AA <input type="checkbox"/> A <input type="checkbox"/> B <input type="checkbox"/> C <input type="checkbox"/> D <input type="checkbox"/>	
	Guide Material	17-4 PH St. St.	
	Plug	Type	Linear
		Guiding	Stem & Port
	Seat Ring	Material (page 3)	Alloy 6 <input type="checkbox"/> Alloy 25 <input type="checkbox"/>
		Type	Retained
Material (page 3)		Alloy 6 <input type="checkbox"/> Alloy 25 <input type="checkbox"/> Hastelloy C <input type="checkbox"/>	
<b>Leakage</b>	ANSI Class	V	
<b>Actuator</b>	Type	Domotor®	
	Size	A	
	Action	Air to Close <input type="checkbox"/> Open <input type="checkbox"/> Fail Close <input type="checkbox"/> Open <input type="checkbox"/>	
	Bench range	3-15 psi <input type="checkbox"/> 6-30 psi <input type="checkbox"/> Other <input type="checkbox"/>	

### Application Data

The checklist below provides a convenient means of listing all the process data required to properly size your 5061 Series Control Valve.

Service Conditions			
Flow Rate		Pressure	
GPM <input type="checkbox"/>	SCFH <input type="checkbox"/>	PSIA <input type="checkbox"/>	<input type="checkbox"/>
LB/HR <input type="checkbox"/>	<input type="checkbox"/>	Temperature °F <input type="checkbox"/> °C <input type="checkbox"/>	
FLUID			
	Min.	Norm.	Max.
Inlet Pressure			
Outlet Pressure			
Flow Rate			
Vapor Pressure			
Critical Pressure			
Temperature			
Superheat			
Sp. Gr. @			
C <sub>t</sub>			
Required C <sub>v</sub>			
Rated C <sub>v</sub>			
ΔP Sizing			
ΔP Shut-off			
Line Size	Inlet:	Outlet:	
Pipe Schedule	Inlet:	Outlet:	
Max. Allowable Noise Level dBA			

The information on page 4 may be used as a guide to specify the 5060 Series Control Valves.

# USEFUL EQUIVALENTS

## U.S. CUSTOMARY UNITS

Specific gravity of air G = 1 (reference for gases)

Specific gravity of water = 1 (reference for liquids)

U.S. gallon of water = 8.33 lbs @ std. cond.

1 cubic foot of water = 62.34 lbs @ std. cond. (= density)

1 cubic foot of water = 7.48 gallons

1 cubic foot of air = 0.076 lbs @ std. cond. (= air density)

Air specific volume = 1/density = 13.1 cubic feet/lb

Air molecular weight M = 29

G of any gas = density of gas/0.076

G of any gas = molecular wt. of gas/29

$$G \text{ of gas at flowing temp.} = \frac{G \times 520}{T + 460}$$

Standard conditions (U.S. customary) are at 14.69 psia & 60°F

### Flow conversion of gas

$$\text{SCFH} = \frac{\text{Lbs/hr}}{\text{density}} \quad \text{SCFH} = \frac{\text{Lbs/hr} \times 379}{M} \quad \text{SCFH} = \frac{\text{Lbs/hr} \times 13.1}{G}$$

### Flow conversion of liquid

$$\text{GPM} = \frac{\text{Lbs/hr}}{500 \times G}$$

### Temperature Conversion

$$F \text{ (Fahrenheit)} = C(9/5) + 32$$

$$C \text{ (Celsius)} = (F - 32) / 9$$

### METRIC CONVERSION TABLES

Multiply	By	To Obtain
<b><u>LENGTH</u></b>		
millimeters	0.039	inches
centimeters	0.394	inches
inches	2.54	centimeters
feet	30.48	centimeters
feet	0.304	meters
<b><u>AREA</u></b>		
sq. centimeters	0.155	sq. inches
sq. centimeters	0.001076	sq. feet
sq. inches	6.452	sq. centimeters
sq. inches	0.00694	sq. feet
sq. feet	929	sq. centimeters
<b><u>FLOW RATES</u></b>		
gallons US/minute (GPM)	3.785	liters/min.
gallons US/minute	0.133	ft <sup>3</sup> /min
gallons US/minute	0.227	m <sup>3</sup> /hr
cubic feet/minute	7.481	GPM
cubic feet/hour	0.1247	GPM
cubic feet/hour	0.01667	ft <sup>3</sup> /min
cubic meters/hour	4.403	GPM
cubic meters/hour	35.31	ft <sup>3</sup> /hr
<b><u>VELOCITY</u></b>		
feet per second	0.3048	meters/second
feet per second	1.097	km/hr
feet per second	0.6818	miles/hr

Multiply	By	To Obtain
<b><u>VOLUME &amp; CAPACITY</u></b>		
cubic feet	28.32	liters
cubic feet	7.4805	gallons
liters	61.02	cubic inches
liters	0.03531	cubic feet
liters	0.264	gallons
gallons	3785.0	cubic cm
gallons	231.0	cubic inches
gallons	0.1337	cubic feet
<b><u>WEIGHT</u></b>		
pounds	0.453	kilogram
kilogram	2.205	pounds
<b><u>PRESSURE &amp; HEAD</u></b>		
pounds/sq. inch	0.06895	bar
pounds/sq. inch	0.06804	atmosphere
pounds/sq. inch	0.0703	Kg/cm <sup>2</sup>
pounds/sq. inch	2.307	ft of H <sub>2</sub> O (4°C)
pounds/sq. inch	0.703	m of H <sub>2</sub> O (4°C)
pounds/sq. inch	5.171	cm of Hg (0°C)
pounds/sq. inch	2.036	in of Hg (0°C)
atmosphere	14.69	psi
atmosphere	1.013	bar
atmosphere	1.033	Kg/cm <sup>2</sup>
atmosphere	101.3	kPa
bar	14.50	psi
kilogram/sq. cm	14.22	psi
kiloPascal	0.145	psi

Facilities: Brazil, Canada, France, Germany, Italy, Japan, Mexico, Netherlands, Singapore, Spain, United Kingdom, United States

Masoneilan North American Operations  
Dresser Valve and Controls Division  
Dresser Industries, Inc.  
Marketing Services  
15112 Morales Road  
P.O. Box 60078 (77205-0078)  
Houston, Texas 77032  
Tel: (713) 986-6500  
Fax: (713) 986-6569

