

# Masoneilan® Model 31/32 Spring Diaphragm Rotary Actuator

Specification Data

CR3132

04/06

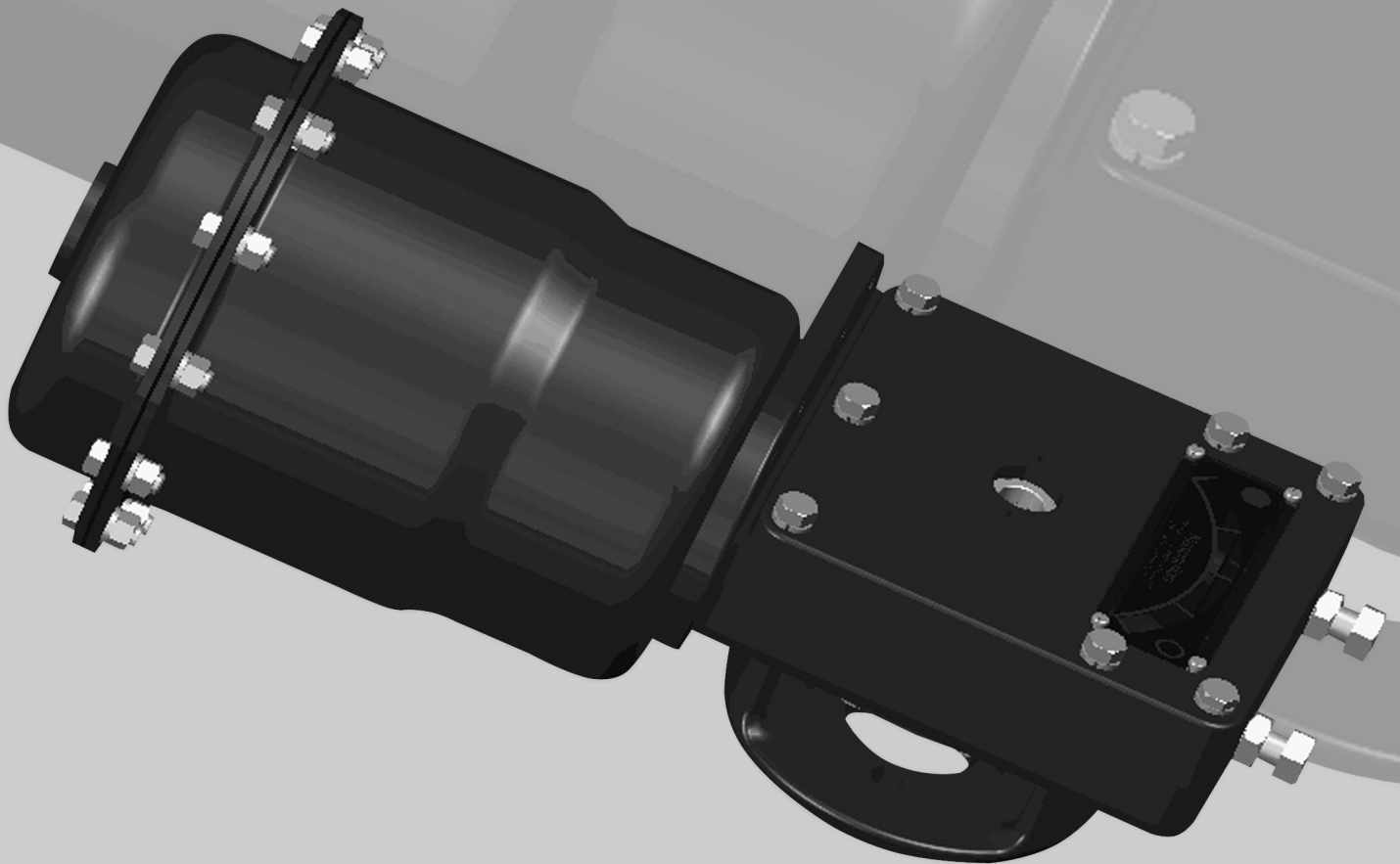

**Pneumatic  
Spring Diaphragm  
Rotary Actuator**



## Table of Contents

Features .....	2
Numbering System .....	2
Specifications .....	3
Materials .....	4-6
Dimensions and Weights .....	7
Sales Offices and Distribution Centers .....	Back Cover

## Features

The Masoneilan model 31 and 32 pneumatic spring diaphragm rotary actuators are designed to provide high performance, reliability and long service life. Product features include:

### Field Reversible

Air action can be changed in the field without additional parts.

### Modular Spring Pack

3 standard spring ranges are achievable using two springs either individually or combined.

### Separate Interchangeable Yoke

Allows flexible mounting options to a variety of rotary valves. Yoke and mounting parts are available for Masoneilan rotary valves as well as a universal mounting that is adaptable to other quarter turn valve designs.

### Diaphragm Cases

Pressed steel upper and lower diaphragm cases combine lightness, high mechanical strength and protection in the event of over pressurization.

### Diaphragm

Molded elastomeric diaphragm with fabric insert for strength, long life and high sensitivity.

### Linearity

The molded rolling diaphragm and deep cases minimize area changes providing a more linear relationship between travel, air pressure and output torque.

### High Power Manual Override

An optional right-angle manual gear (handjack) override is available for all configurations.



For additional information, please consult your local Masoneilan Sales Representative.

## Numbering System

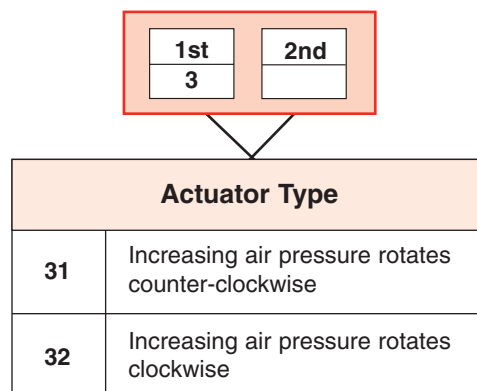

# Specifications

## Output Torque - lbs-in

Spring Range	Air Supply - psi											
	40		50		60		70		80		90	
psi	Air End	Spring End	Air End	Spring End	Air End	Spring End	Air End	Spring End	Air End	Spring End	Air End	Spring End
	Output Torque lbs-in											
12-28	1584	1535	2855	1535								
17-40					2633	2184	3907	2184				
29-68									1675	3718	2947	3718

## Output Torque - N-m

Spring Range	Air Supply - bar											
	2.76		3.45		4.14		4.83		5.52		6.21	
psi	Air End	Spring End	Air End	Spring End	Air End	Spring End	Air End	Spring End	Air End	Spring End	Air End	Spring End
	Output Torque N-m											
12-28	179	173	322	173								
17-40					297	247	441	247				
29-68									189	420	333	420

## General Data

Model	Size	Spring Range		Effective Area		Actuator Stroke		Handwheel Diameter	
		psi	kPa	sq. in.	sq. cm	inches	mm	inches	mm
31/32	D	12-28	83-193	60	387	4.000	101.6	8	203
	D	17-40	117-276	60	387	4.000	101.6	8	203
	D	29-68	200-469	60	387	4.000	101.6	8	203

# Materials

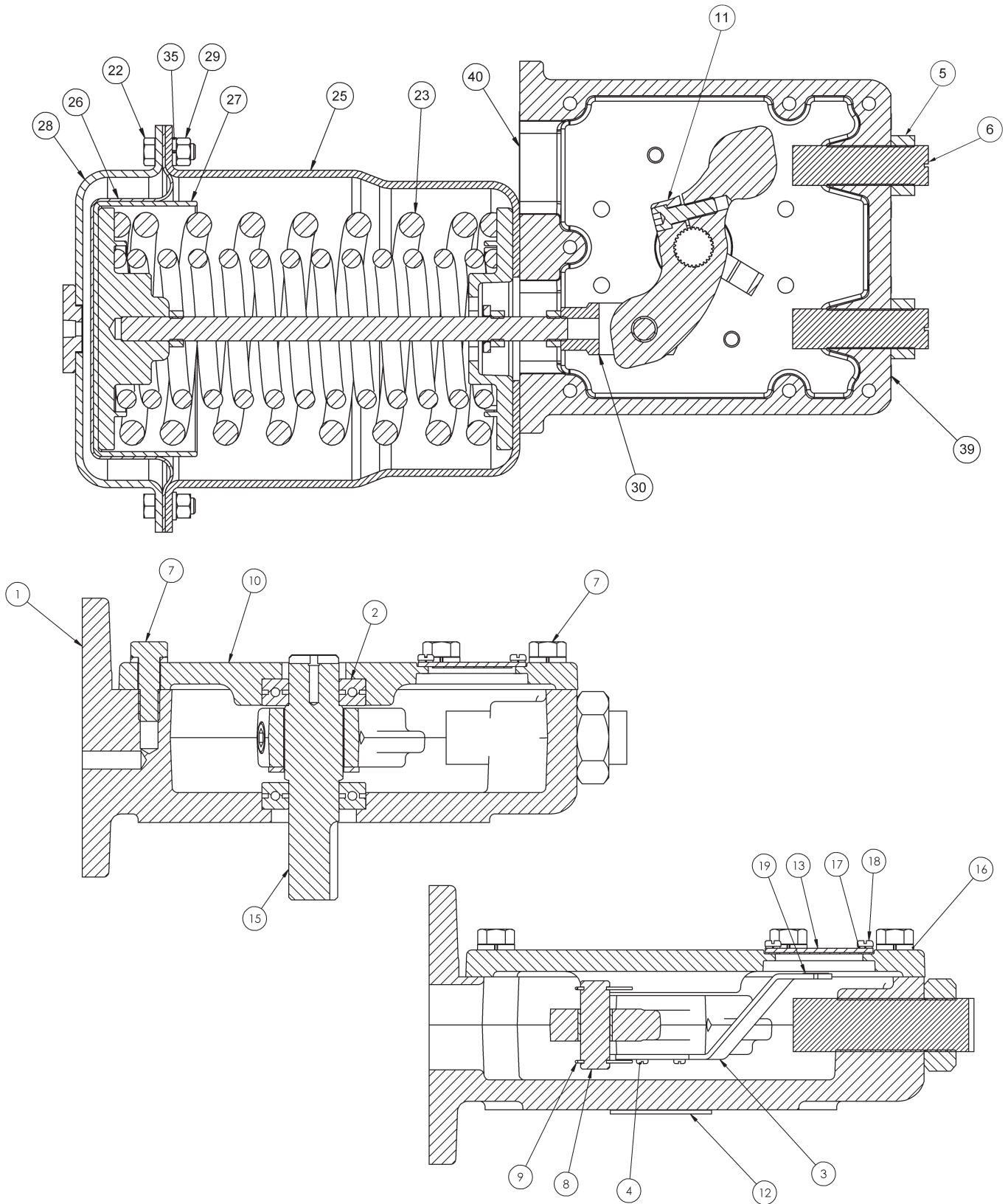

Size D Actuator

# Materials

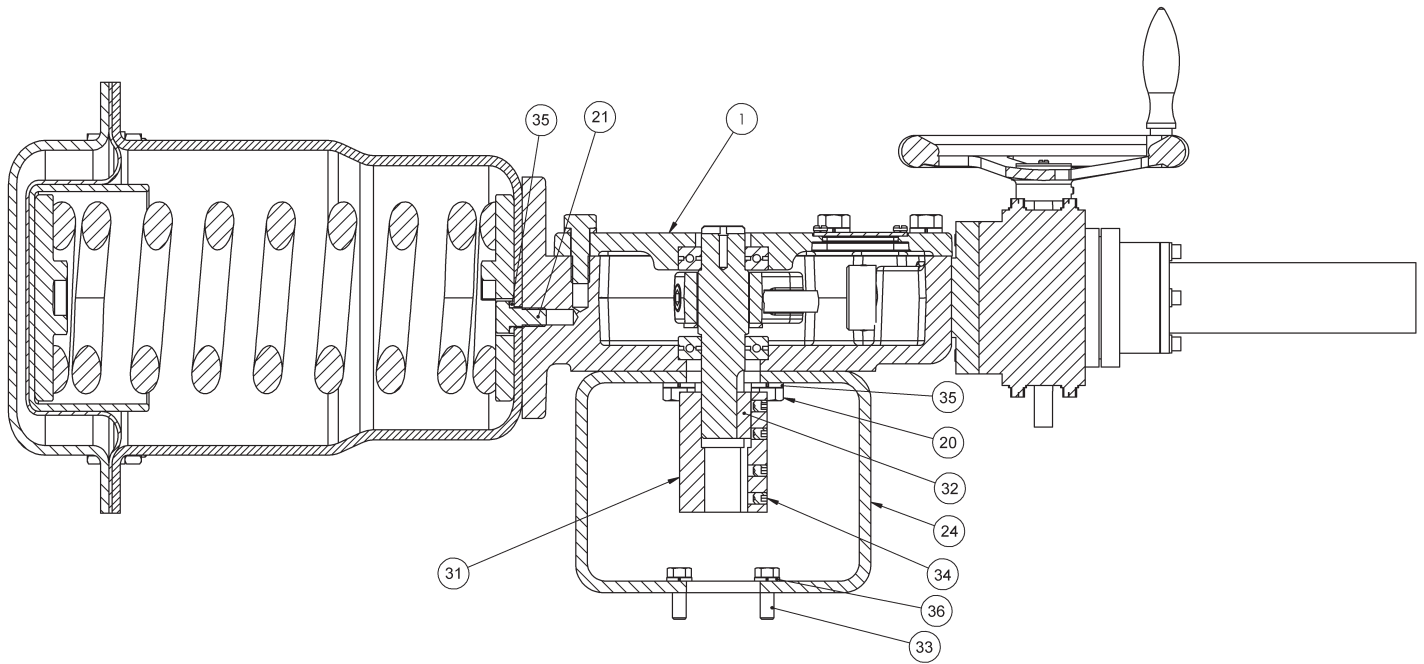

**Size D Actuator**  
**Shown with Universal Mounting and Optional Handjack Manual Override**

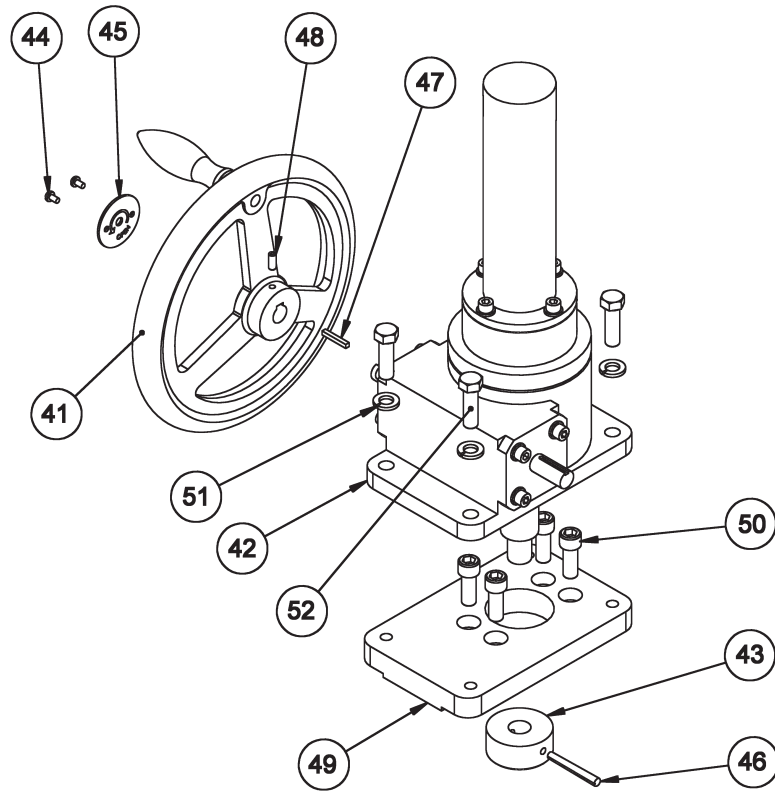

**Optional Handjack Manual Override**

## Materials

Ref. No.	Description	Material
1	Housing	Ductile Iron
2	Ball Bearing	Various
3	Indicator Pointer	Stainless Steel
4	Pan Head Screw	Carbon Steel
5	Hex Jam Nut	Carbon Steel
6	Travel Stop	Carbon Steel
7	Hex Head Cap Screw	Carbon Steel
8	Clevis Pin	Stainless Steel (17-4 PH)
9	Circlip	Stainless Steel
10	Housing Cover	Ductile Iron
11	Lever S/A	Various
12	Grommet	Neoprene Rubber
13	Front Cover S/A	Polycarbonate
15	Shaft - Universal Mounting Only	Stainless Steel (17-4 PH)
16	Lockwasher	Carbon Steel
17	Lockwasher	Carbon Steel
18	Pan Head Screw	Carbon Steel
19	Indicator Dot	Vinyl
20	Hex Head Cap Screw	Carbon Steel
21	Hex Head Cap Screw	Carbon Steel
22	Hex Head Cap Screw	Carbon Steel
23	Spring S/A	Various
23a	Spring, Outer	Carbon/Alloy Spring Steel
23b	Spring, Inner	Carbon/Alloy Spring Steel
23c	Piston	Ductile Iron
23d	Piston Rod	Alloy Steel
23e	Washer	Carbon Steel
23f	Hex Jam Nut	Carbon Steel
23g	Lower Spring Guide	Ductile Iron
24	Yoke Adapter	Ductile Iron
25	Lower Diaphragm Case	Carbon Steel

Ref. No.	Description	Material
26	Diaphragm	Buna-N w/Polyester
27	Diaphragm Retainer	Carbon Steel
28	Upper Diaphragm Case S/A	Carbon Steel
29	Hex Nut	Carbon Steel
30	Clevis	Carbon Steel, Zinc Plate
31	Coupling - Universal Mounting Only	Carbon Steel
32	Key - Universal Mounting Only	Carbon Steel
33	Hex Head Cap Screw - Universal Mounting Only	Carbon Steel
34	Cup Point Set Screw - Universal Mounting Only	Carbon Steel
35	Lockwasher	Carbon Steel, Zinc Plate
36	Lockwasher - Universal Mounting Only	Carbon Steel, Zinc Plate
37	Warning Plate	Stainless Steel (not shown)
38	Information Plate	Stainless Steel (not shown)
39	Hole Cover	Aluminum (not shown)
40	Hole Cover	Aluminum (not shown)
41	Handwheel	Aluminum
42	Jack Screw Manual Override	Various - Assembly
43	Button End	Stainless Steel
44	Pan Head Screw	Carbon Steel
45	Handwheel Plate	Polycarbonate
46	Taper Pin	Stainless Steel
47	Square Key	Carbon Steel
48	Cup Point Set Screw	Carbon Steel
49	Adapter Plate	Stainless Steel (17-4 PH)
50	Socket Head Cap Screw	Carbon Steel
51	Lockwasher	Carbon Steel
52	Hex Head Cap Screw	Carbon Steel

# Dimensions and Weights

Dimensions: inches (mm)

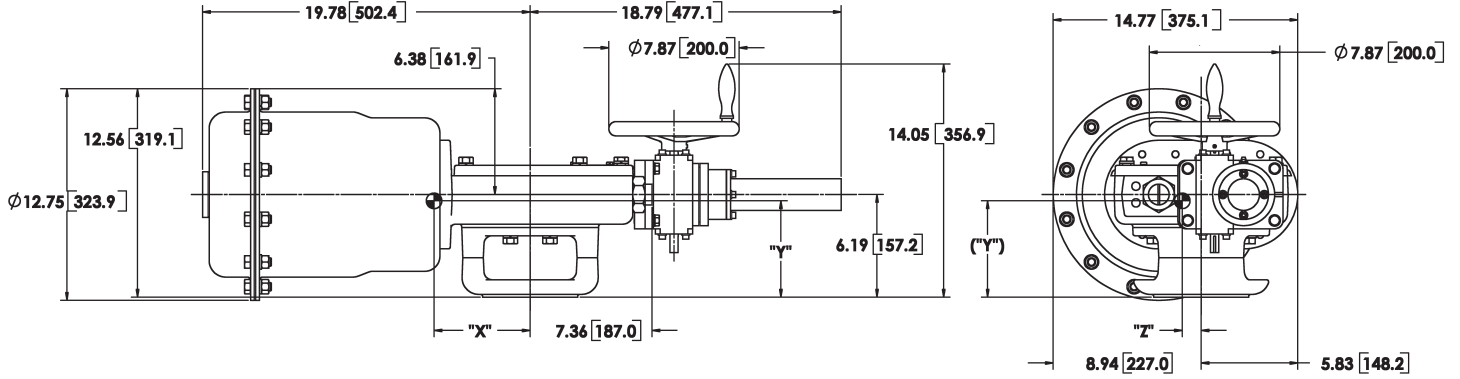

Cast Yoke Adapter

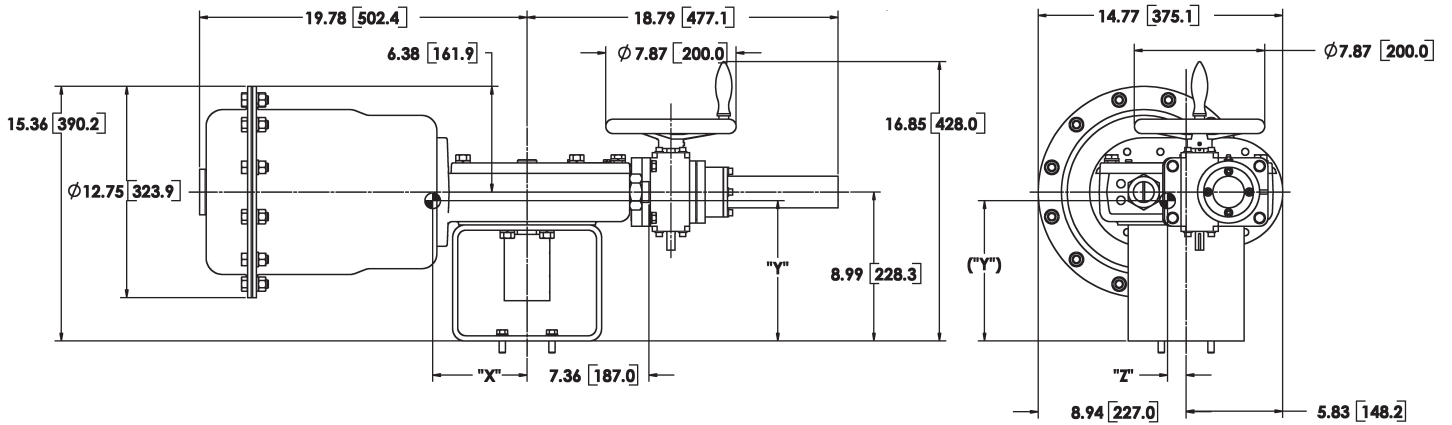

Universal Mounting - Fabricated Yoke Adapter

Configuration	Weight		Center of Gravity					
			X		Y		Z	
	lbs	kg	inches	mm	inches	mm	inches	mm
Without Manual Override, Cast Yoke Adaptor	183	83	-6.72	-170.7	5.66	143.8	1.30	33
With Manual Override, Cast Yoke Adaptor	194	88	5.80	147.3	5.81	147.6	1.15	29.1
Without Manual Override, Fabricated Yoke Adapter (Universal Munting)	186	84	-6.60	-167.6	8.31	211.1	1.28	32.4
With Manual Override, Fabricated Yoke Adapter (Universal Munting)	198	90	-5.70	-144.8	8.46	214.9	1.13	28.6

# Sales Office Locations

## BELGIUM

Dresser Valves Europe  
Boulevard du Souverain 207 B2 Vorstlaan,  
B-1160 Brussels, Belgium  
Phone: +32-2-344-0970  
Fax: +32-2-344-1123

## BRAZIL

Dresser Industria e Comercio Ltda  
Divisao Masoneilan  
Rua Funchal, 129 - Conj. 5A  
04551-060 - Sao Paulo - SP Brazil  
Phone: 55-11-2146-3600  
Fax: 55-11-2146-3610

## CANADA

Ontario  
Dresser - Masoneilan  
DI Canada, Inc.  
835 Harrington Court, 2nd Floor  
Burlington, Ontario L7N 3P3, Canada  
Phone: 905-335-3529  
Fax: 905-336-7628

## CHINA

Dresser Flow Solutions, Beijing Rep. Office  
Suite 1703, Capital Mansion  
6 Xinyuannan Rd. Chaoyang District  
Beijing 100004, China  
Phone: +86-10-8486-4515  
Fax: +86-10-8486-5305

## FRANCE

Masoneilan - Dresser Produits Industriels  
Energy 5  
130/190 Boulevard de Verdun  
92413 Courbevoie cedex, France  
Phone: +33-1-4904-9000  
Fax: +33-1-4904-9010

Dresser Produits Industriels S.A.S.,  
Masoneilan Customer Service Centre  
55 rue de la Mouche, Zone Industrielle  
69540 Irigny, France  
Phone: +33-4-72-39-06-29  
Fax: +33-4-72-39-21-93

## GERMANY

Dresser Valves Europe GmbH  
Heiligenstrasse 75  
Viersen D-41751, Germany  
Phone: +49-2162-8170-0  
Fax: +49-2162-8170-280

Dresser Valves Europe GmbH  
Uhlhandstrasse 58  
60314 Frankfurt, Germany  
Phone: +49-69-439350  
Fax: +49-69-4970802

## INDIA

Dresser Valve India Pvt. Ltd.  
305/306, "Midas", Sahar Plaza  
Mathurdas Vasanji Road  
J.B. Nagar, Andheri East  
Mumbai, 400059, India  
Phone: +91-22- 8354790  
Fax: +91-22-8354791

Dresser Valve India Pvt. Ltd.  
205, Mohta Building  
4 Bhikaiji Cama Place  
New Delhi, 110 066, India  
Phone: +91-11-2-6164175  
Fax: +91-11-5-1659635

## ITALY

Dresser Italia S.r.l.  
Masoneilan Operations  
Via Cassano, 77  
80020 Casavatore, Napoli Italy  
Phone: +39-081-7892-111  
Fax: +39-081-7892-208

## JAPAN

Niigata Masoneilan Co. Ltd. (NIMCO)  
20th Floor, Marive East Tower  
WBG 2-6 Nakase, Mihama-ku,  
Chiba-shi, Chiba 261-7120 Japan  
Phone: +81-43-297-9222  
Fax: +81-43-299-1115

## KOREA

Dresser Korea Inc.  
2109 Kuk Dong Building 60-1  
3-Ka, Choongmu-ro Chung-Ku  
Seoul, Korea  
Phone: +82-2-2274-0748  
Fax: +82-2-2274-0720

## KUWAIT

Dresser Flow Solutions  
Middle East Operations  
10th Floor, Al Rashed Complex  
Fahad Salem Street, P.O. Box 242  
Safat, 13003, Kuwait  
Phone: +965-9061157  
Fax: +965-3987879

## MALAYSIA

Dresser Flow Solutions  
Business Suite, 19A-9-1, Level 9  
UOA Centre, No. 19, Jalan Pinang  
50450 Kuala Lumpur, West Malaysia  
Phone: +60-3-2161-0322  
Fax: +60-3-2163-3612

## MEXICO

Dresser Valve de Mexico, S.A. de C.V.  
Henry Ford No. 114, Esq. Fulton  
Fraccionamiento Industrial  
San Nicolas  
54030 Tlalnepantla Estado de Mexico  
Phone: 52-5-310-9863  
Fax: 52-5-310-5584

## THE NETHERLANDS

Dresser Valves Europe  
Steenhouwerstraat 11  
3194 AG Hoogvliet, The Netherlands  
Phone: +31-10-438-4122  
Fax: +31-10-438-4443

## RUSSIA

DS Controls  
Nekhinskaya Street, 61  
Veliky Novgorod  
Russia, 173021  
Phone: +7-8162-15-7898  
Fax: +7-8162-15-7921

## SAUDI ARABIA

Dresser AL Rushaid  
Valve & Instrument Co., Ltd.  
(Darvico)  
P.O. Box 10145  
Jubail Industrial City 31961,  
Saudi Arabia  
Phone: +966-3-341-0278  
Fax: +966-3-341-7624

## SINGAPORE

Dresser Singapore Pte Ltd.  
16 Tuas Avenue 8  
Singapore 639231  
Phone: +65-6-6861-6100  
Fax: +65-6-6861-7172

## SOUTH AFRICA

Dresser Limited  
P.O. Box 2234  
16 Edendale Road  
Eastleigh, Edenvale 1610  
Republic of South Africa  
Phone: +27-11-452-1550  
Fax: +27-11-452-6542

## SPAIN

Masoneilan S.A.  
C/Murcia 39 C  
08830 Sant Boi de Llobregat  
Barcelona, Spain  
Phone: +34-93-652-6430  
Fax: +34-93-652-6444

## UNITED ARAB EMIRATES

Dresser Flow Solutions  
Middle East Operations  
P.O. Box 61302  
Roundabout 8  
Units JA01 & JA02  
Jebel Ali Free Zone  
Dubai, U. A. E.  
Phone: +971-4-8838-752  
Fax: +971-4-8838-038

## UNITED KINGDOM

DI U.K. Ltd.  
East Gillibrands  
Skelmersdale,  
Lancashire WN8 9TU,  
England  
Phone: +44-1695-52600  
Fax: +44-1695-52601

DI U.K. Ltd.  
Unit 4, Suite 1.1,  
Nobel House  
Grand Union Office Park  
Packet Boat Lane  
Uxbridge, Middlesex UB8  
2GH  
Phone: +44-1895-454-900  
Fax: +44-1895-454-919

## UNITED STATES

Dresser - Masoneilan  
85 Bodwell Street  
Avon, MA 02322-1190  
Phone: 508-586-4600  
Fax: 508-427-8971

Dresser - Masoneilan  
4841 Leopard Street  
Corpus Christi, TX  
78408-2621  
Phone: 361-877-2414  
Fax: 361-584-1196

Dresser - Masoneilan  
Dresser Direct  
1250 Hall Court  
Deer Park, TX 77536  
Phone: 281-884-1000  
Fax: 281-884-1010

Dresser Flow Solutions  
(Contractor Sales)  
16240 Port Northwest Drive  
Houston, TX 77041  
Phone: 832-590-2303  
Fax: 832-590-2529

Dresser - Masoneilan  
2950 East Birch Street  
Brea, CA 92821  
Phone: 714-572-1528  
Fax: 714-572-1463



CR3132 SD - 04/06  
Model 31/32 Spring Diaphragm  
Rotary Actuator